



The Outside, **Inside**

CONSTRUCTION GUIDE

For Garden Tunnels 8ft Wide

Thank you for purchasing a 'Premier' polytunnel.

Please take the time to carefully read through this Construction Guide before you head out into your garden and begin building your 'Premier' polytunnel.

A polytunnel is not a difficult structure to construct, but the task at hand should not be taken lightly – After all, this is a building that must stand up to extreme weather conditions year after year, and should not be thought of as a tent. This really is a two person job, so why not invite a friend to join you and make a weekend of it.

The following is a Guide to the successful construction of your polytunnel. If you follow this Guide, you will have many years of growing pleasure from your polytunnel with very little or no maintenance. Please use the **Checklist** supplied with your order, together with this Guide, to help you identify the different parts of your polytunnel.

If you are unsure or confused about any aspect of construction, please feel free to contact us via e-mail at info@premierpolytunnels.co.uk or by telephone on 01282 811250.

Premier Polytunnels are proud to be the **ONLY** polytunnel supplier to offer an out of hours Construction Advice Service, available until 9pm, 7 days a week.

We have covered some of the polytunnel options within this Construction Guide that may not relate to the polytunnel and extras/additions you have purchased. Please ignore any sections which do not apply.

CONTENTS

SECTION	PAGE
Introduction	3
Site	4
Foundation Tubes	5
Cover Tensioning Foundation Tubes	6 - 7
Anchor Plates	8
Base Plates	9
Hoops	10
Storm Strengthening Kit	11
Ridge – and – Triple Ridge Kit	11
Corner Stabilisers	12
Crop Bars	13
Staging Supports	14 - 15
Dummy Door / End Frame	16 - 17 - 18 - 19
Door Frame	20 - 21 - 22
Forming a Rebate for your Door Frame	23
Doors	23 - 24 - 25
Final Fix	25
Anti Hot Spot Tape	26
Covering Your Polytunnel – Trenching Option	26 - 27 - 28 - 29
Timber Base Rails	29 - 30
Forming a Rebate for your Base/Side Rails	30
Covering Your Polytunnel – Base Rails Option	31
Timber Side Rails	32
Covering Your Polytunnel – Side Rails Option	32

TOOLS REQUIRED

A spirit level is not a necessary instrument in this construction where a good eye will do, but the more care that is taken to ensure everything aligns, the better the finished project will look.

*****WARNING: PRODUCTS MAY CONTAIN SHARP EDGES.
ALWAYS WEAR GLOVES.*****

Here is a list of tools required to complete the construction of your polytunnel:

Tape measure	Spade	Large hammer	Claw hammer
Timber drift	2 x 13mm spanner	Marker pen	Battery Drill
9mm drill bit	Philips screwdriver	Wood saw	String Line
Sharp Knife			

Please note: If and when extra tools are required for any optional extras/polytunnel additions which you may have purchased, these are listed at each stage.

INTRODUCTION

“Picture this...”

Below is a simple outline of what you should end up with once you have completed your project and is something to bear in mind while constructing your polytunnel.

A polytunnel is a series of hoops placed in line on **Foundation Tubes**.

A **Ridge** tube is suspended under the hoops at the centre point and runs the full length of the polytunnel.

Four diagonal tubular **Stabilisers** are placed one at each corner.

A timber **door/end frame** is fixed central at each end.

A trench is dug around the outside of the framework – **OR** – **Base Rails** are placed around the polytunnel at ground level.

Polythene is placed over the framework and fixed around the door frame. The polythene cover is then buried in the trench – **OR** – fixed to the **Base Rails**.

OPTIONAL EXTRAS/POLYTUNNEL ADDITIONS - If ordered:

Anchor Plates clamp to the base of each **Foundation Tube** in a 16-inch hole, before soil is compacted back over them to prevent the polytunnel framework from lifting or sinking.

Crop Bars are horizontal tubes placed across each intermediate hoop at roughly head height.

Base Rails run around the outside of the framework at ground level and the cover is fixed to these rails.

Side Rails are identical to **Base Rails**, but are placed on the framework at the top of the straight side on either one or both sides. **Sides Rails** include ventilation net.

Where two tubes connect a simple fixing method using two **“P Clips”** is always necessary.

The images below demonstrate the use of **P Clips**.



*****PLEASE NOTE: When assembling your polytunnel, no screws, bolts, ends of tubes, etc, should protrude beyond the hoops as these will cause damage to your cover.*****

SITE

Your construction site should be clear and reasonably level from side to side. Approximately 6-inch out of level can be taken up by adjusting the Foundation Tubes of your polytunnel . A slope from end to end does not have to be taken into account as your polytunnel can be built straight onto this slope with the framework placed at the vertical.

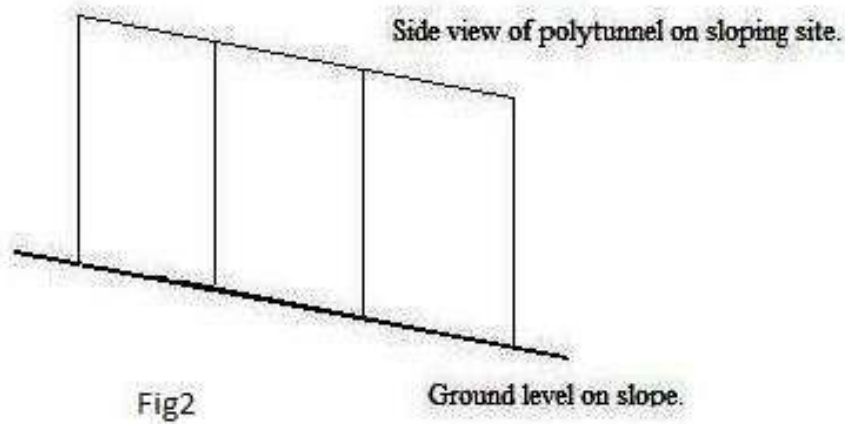
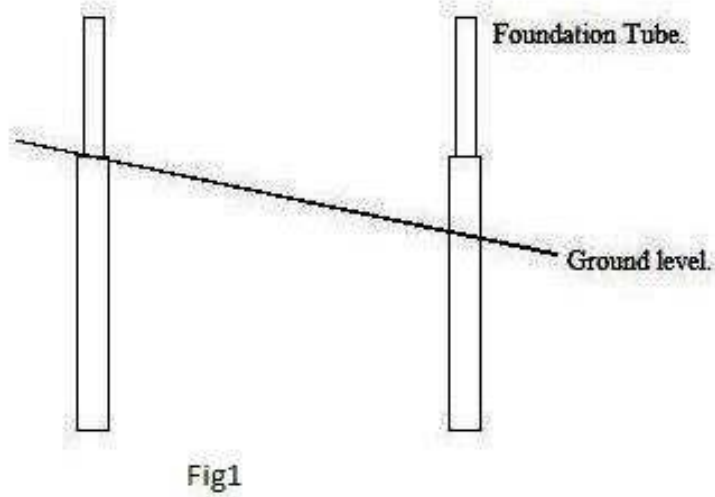

Fig1 shows a slope from side to side and how up-to-a 6-inch slope can be removed by adjusting the foundation tubes.

Fig2 shows a slope from end to end.

FOUNDATION TUBES

*****IMPORTANT – Protect the ends of tubes from damage when driving them into place by using a timber drift.*****

If you have ordered Cover Tensioning Foundation Tubes, please skip to the next section.

Foundation Tubes are driven into the ground at each end of each hoop. Choose a corner of your polytunnel to be a fixed point from which all measurements will be taken and drive in a Foundation Tube using a timber drift to protect the end, leaving only the swage protruding above ground. (The “swage” is the end of the tube which has been reduced in diameter). Measure the length of your chosen polytunnel and drive in a second tube. (All measurements are to the centre of the tube). Mark out the remaining corners, but do not drive in the Foundation Tubes yet. The measurements for these will be the width and length of your polytunnel. To check for square, measure from corner to corner (**Fig 3**) – This measurement should be the same, but if not, simply adjust the two tubes along the length until correct.

Mark out the position for the remaining Foundation Tubes down the length of the polytunnel at 5ft spacing and drive in Foundation Tubes. Use a string or straight edge to check the tops are level and the tubes are in line.

DO NOT screw hoops to the Foundation Tubes until you come to the **Final Fixing** stage (see Page 23).

*****If Anchor Plates or base plates have been purchased, please see the section on ‘Anchor Plates’ or ‘Base Plates’ before driving in the Foundation Tubes.*****

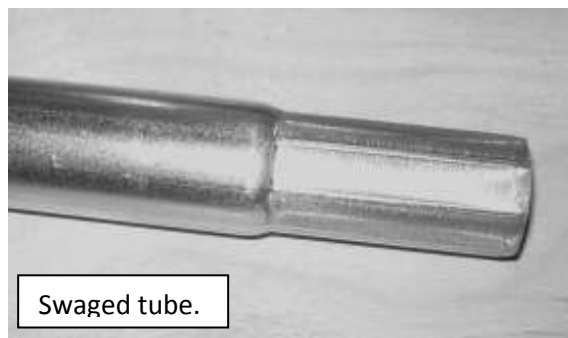

Distance across corners should be equal for square.

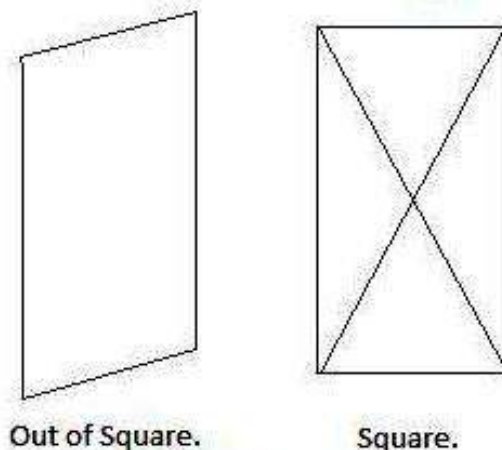

Fig3

COVER TENSIONING FOUNDATION TUBES

****ONLY REQUIRED WHEN TRENCHING IN THE COVER****

These foundation tubes replace the standard tubes and are plain at both ends (no swage). They should be positioned just as you would if using the standard foundation tubes, and the only difference is that 8-inch of tube must be left protruding above ground.

Set the four corner tubes and line up the intermediate tubes from these.

If you are using Anchor Plates, set these as described in the relevant section of this Construction Guide.

Polytunnels with 28mm diameter steel hoops

The polytunnel hoops placed **INSIDE** the **35mm** diameter foundation tubes.

Place a Tensioning Tube Clamp around the hoop 8-inches up from the base of the straight side and slot the hoop into the foundation tube.

After trenching in the cover and completing the polytunnel, the Tensioning Tube Clamps can be loosened, if necessary, and the hoops can be raised to add additional tension to the cover.

Fig A – Shows the polytunnel hoops **INSIDE** the foundation tube at ground level.

Fig B – Shows the hoop raised and fixed with the tightened clamp at the top of the foundation tube.

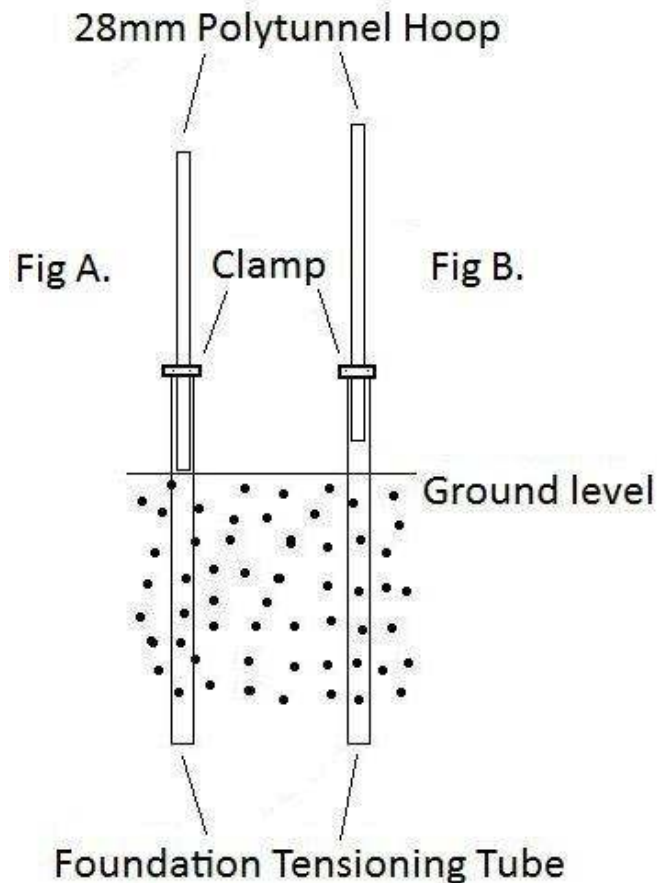



Raising the hoop (and clamp) to tension cover.



Clamping the hoop into position at the top of the foundation tube.

ANCHOR PLATES

Anchor Plates replace the need for concrete in soft ground and must be used when Base Rails are used to prevent lifting. After marking out the position of all the Foundation Tubes **WITHOUT** driving any tubes in, dig a hole 12-inch square and 14-inch deep at each point. Drive the Foundation Tubes into the bottom of each corner hole until only the swage remains above ground (**Fig4**) while checking all measurements, for level and square. Place an Anchor Plate Clamp (**Fig5**) around the Foundation Tube at the bottom of the hole (**Fig6**). An Anchor Plate slots over the tube to rest on the clamp and another clamp is tightened on top of the plate to hold it in position (**Fig7**). The soil is placed back in the hole and heeled down, leaving only the “swage” protruding (**Fig8**). Repeat this process for all the intermediate holes using a string line or straight edge to make sure they are in line and level. Re-check all measurements.



Fig4



Fig5



Fig6



Fig7



Fig8

BASE PLATES

Tools required:

Hammer drill.
14mm masonry bit.

If you have ordered Base Plates, please use the same method of positioning as for Foundation Tubes.



**Base Plates come in one of two types –
Garden and Commercial –
dependant on the size of polytunnel.**



Base Plates are supplied with loose bolts.

HOOPS

Hoops come in three pieces – two outer legs and one inner hoop. These pieces should be slotted together on a flat base and each joint held in place using a self drill screw which should be 20mm away from the joint (**Fig9**).

Lift the hoops into position on the Foundation Tubes, making sure the screws on the end hoops face the inside of the polytunnel (**Fig10**).



Fig9



Self Drill Screw



Fig10 – Hoops in position on Foundation Tubes.

*****Please note: Self drill screws should be held in the nut driver provided or can be held directly into a drill chuck. They will drill their own hole and tap themselves into position. Do not over-tighten.*****

*****If you have purchased a Storm Strengthening Kit, please ensure the self drill screw joining the hoops is at least 20mm away from the actual joint, but not so far away that it misses the two parts of the hoop. This will allow room for fitting the storm/joint strengthening collar – See next section on Storm Strengthening Kit.*****

STORM STRENGTHENING KIT

This is a very simple method of adding strength to the weakest part of the hoop. Simply bolt a P Clip around the joints of each hoop (acting as a collar), making sure that the leg of the 'P' does not interfere with the polythene cover.



Storm Strengthening collar

RIDGE – and – TRIPLE RIDGE KIT

The centre ridge bars (standard on all polytunnels) are supplied in 5ft sections. (One starter ridge with plain ends and extensions with one swaged end). The length of these pieces will correspond to the hoop spacings of your polytunnel.

Place a P Clip around the centre of each hoop. On the end hoops the leg of the 'P' should face inwards and on all hoops the leg should be to the bottom (**Fig11**).

Measure and mark, or use your eye to find centre. Use a self drill screw to lock the ridge sections and P Clips together. Fit a plastic end cap in each end of the ridge.

Triple Ridge Kits. These side ridge bars are identical to the centre ridge and should be assembled using the same method. **Please Note:** If you have ordered a Crop Bar Kit or a Storm Strengthening Kit, you should assemble these items prior to your side ridges in order that your ridge bars can avoid these items.

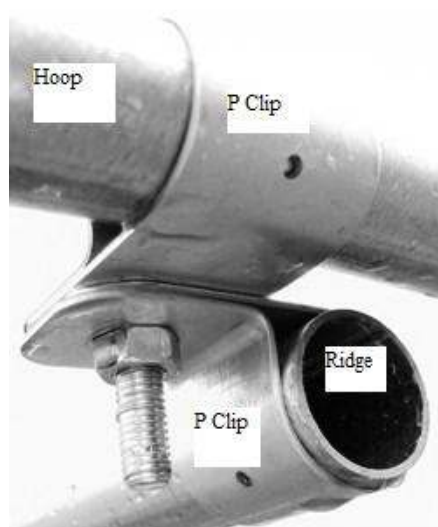

Fig 11



Completed Centre Ridge.

CORNER STABILISERS

These tubes are placed to form a triangle at each corner of the polytunnel (**Fig12**). They should start 9-inch up from the ground on the second to end hoop (**Fig13**) and angle up to the end hoop. Before tightening the clamps on the end hoop, adjust the hoop until vertical and both sides in line. Fit a plastic end cap in both ends of the tube.



***Correct clamp position -
Inside the end hoop.**



***Wrong clamp position -
Protuding outside the end hoop.**



Fig12



Fig13

CROP BARS

Crop Bars are horizontal bars which fit across an intermediate hoop at approximately head height (**Fig14**).

Fit a plastic end cap in both ends of the tube (**Fig15**).



Fig14



**Fig15 – End cap inserted into tube,
and loose end caps.**

STAGING SUPPORTS

A staging support is made up of three 28mm diameter tubes – These should have a plastic end cap inserted in each end. The horizontal top tube which fixes to the leg of a hoop is 750mm long – This is attached by using two P Clips just as in all the other tube joints on your polytunnel. At the inner end of this bar a 750mm vertical leg is attached at right angles, once again with two P Clips.

When the top bar and vertical leg are at right angles ('approximately' is near enough) the 300mm-long diagonal brace is fixed across the corner using two P Clips at each end.

To allow extra leg room and to avoid hitting the staging leg when passing with a wheelbarrow, etc, why not set the staging leg 3-4 inch back from the outer end of the horizontal top tube (not shown in diagram on page 13) – This also helps to spread the weight more evenly across the top.

Please Note: Position the P Clips so that the vertical leg sits underneath the top tube not to the side of it. The top tube should butt up to the hoop, not to the side.

We suggest that you fix the two end staging supports first and level them. These should angle in slightly from the end of the polytunnel to avoid the cover. Position the centre supports and align them with the ends. Use a hard pad to stand the leg on when placing the support on a soft base – This will help prevent the leg from sinking.

Finally, lock all P Clips in place with a self drill screw.

A suggestion for an economy staging top is a front rail of 3-inch x 2-inch timber, which is bolted with a single P Clip and M8 x 75mm Cup Square Bolt towards the front edge of the support top – Before drilling the timber make sure the support leg is vertical. Another length of 3-inch x 2-inch timber is placed towards the rear edge of the support (not fixed). These two timbers will then support a solid top or cross laths.

You may prefer to assemble the staging supports as a sub-assembly prior to fitting to the polytunnel hoops.



Completed Staging Supports, with loose P Clip for fixing your own timber top.



Polytunnel staging complete with top.

Garden Polytunnel Staging Support

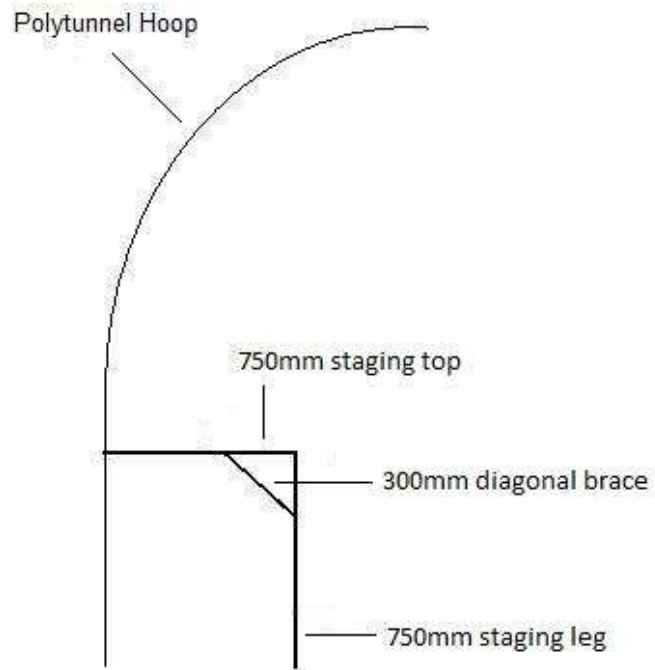

DUMMY DOOR / END FRAME

3-inch x 2-inch timber is used for the end frame.

Using a flat surface or bench take the 3-inch x 2-inch x 2.4m end frame posts and measure 10.5-inch down from one end of each post and make a mark (**Fig16**).



Fig16



Fig17

Insert a piece of pre-cut 3-inch x 2-inch x 713mm timber between the posts, lining up the top edge with the previously made marks (**Fig17**).

To fix the cross piece, drill a 7mm hole through the side of each post (**Fig18**) in line with the centre of the cross piece. Place a 6-inch nail through these holes and nail into the cross piece (**Fig19**).



Fig18



Fig19

Nail a plate across each of the joints on one side only (**Fig20**).



Fig20

Measure 35.5-inch down the posts from the top edge of the first cross piece and make a mark. Drill a 7mm hole through the side of the posts on this mark and fix the second cross piece in place using the same method as with the first, making sure that the mark is the centre of the cross piece (**Fig21**).

Tack a net panel to the top half of the end frame – (this should be on the opposite side to the nail plates) – and polythene to the bottom half. Get as much tension as possible on the polythene panel – a staple gun comes in handy here.

Cut a piece of 19mm x 38mm timber batten the full width of the end frame and nail this along the top edge of the first cross piece to trap the net panel – This batten also forms the rebate in which the main cover will be trapped. A nail positioned each side of the joint where the cross piece meets the post will add stiffness to the frame (**Fig22**).



Fig21



Fig22

Take two full 1.8m lengths of batten and nail these down the outside edge of the posts, butted up to the top batten (**Fig23**). Put tension into the net and polythene panel as you nail the battens.



Fig23



Fig24

Next, nail another batten across the middle of the second cross piece, overlapping both the net and the polythene panels. This batten should be cut down slightly so that it is just a little bit (approx 5mm) shorter than the second cross piece to which it is fixed and must not overlap onto the post. This ensures enough space for the main cover and the batten which traps it (**Fig24**).

Trim off the excess net and polythene from around the edges, but leave the bottom of the polythene panel as this will be buried in the trench along with the bottom of the posts (**Fig25**).



Fig25

HANGING THE END FRAME

Dig a trench approximately 12-inch deep and the width of the end frame. This trench should be central under the end hoop to which the end frame will be fixed (**Fig26**).



Fig26

Hold the end frame in position with the legs and polythene in the trench and the top of the posts against the hoop. Centralise the end frame in the end hoop and mark the posts under the hoop (**Fig27**). It is recommended when marking the posts that they are kept as short as possible whilst maintaining a reasonable amount at the base to be buried – This will aid air circulation.



Fig27

Cut the posts on the marks and reposition in the trench with the tops under the hoop. Place a P Clip around the hoop, with the leg of the 'P' down the outside of the post. Centralise the end frame and mark through the hole in the P Clips **(Fig28)**. Drill through the posts on this mark with a 9mm drill. Bolt the P Clip to the posts using a cross head roofing bolt with a washer under the nut **(Fig29)**. Remember the leg of the P Clip should be down the outside face of the post with the least amount of timber protruding past the outside face of the hoop. Check the frame for central and lock the P Clips to the hoop with a self drill screw on the inside.



Fig28



Fig29

Back fill the trench keeping the end frame in line with the hoop **(Fig30)**.



Fig30

DOOR FRAME

3-inch x 2-inch timber is used for door frame.

It may help to place a string line across the end hoop – This can then be used as a line for the door frame, or just use your eye to line the frame with the end hoop.

The door opening will be 810mm if using the standard door supplied with your kit.

Mark the end hoop 405mm each side of centre (this is where the door posts will fix) **(Fig31)** and dig a hole approximately 12-inch deep directly below this mark. Decide which way you want your door to open and position the 8ft door post, which will carry the door hinges, into the hole with the inside edge on the mark on the hoop. Check the post for vertical and mark the timber under the hoop **(Fig32)** – Cut the post on this mark. Place a P Clip on the hoop with the leg of the 'P' to the outside. Re-position the post in the hole and on the mark on the hoop, then with the P Clip running down the outside face of the post, drill the post and fix to the hoop. This method reduces the amount that the post protrudes past the outside edge of the hoop **(Fig33)**. **Please Note:** A washer must be used behind the nut **(Fig34)**. Back fill the hole with soil making sure the post remains vertical and in line with the end hoop. Lock the P Clip to the hoop with a self drill screw **(Fig35)**.

Hang the door on this post leaving adequate room at the bottom for the door to open without catching **(Fig36)**.

Place the second door post in its hole and hold up to the door leaving a gap of approximately 6mm between the door and post (use a 6-inch nail or screwdriver shaft to get this gap). Mark the post under the hoop and cut. Hang the post using the same method as used when hanging the first post and, when you are happy with the position and the gap, back fill the hole and secure the P Clip **(Fig37)**.

You may be unable to use the pre-drilled holes in the P Clip, but the screw will make its own hole in a place suitably clear of the polythene.



Fig31



Fig32



Fig33



Fig34

SECURING THE FIRST POST

Top of door post locked to the end hoop with a P clip on the front face of the post

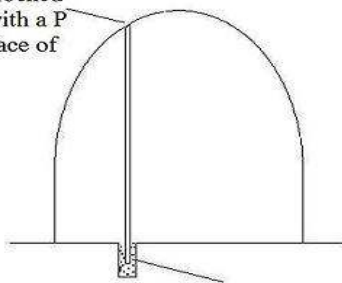

Base of door post buried in earth or fixed with base plate

Fig35

HANGING THE DOOR

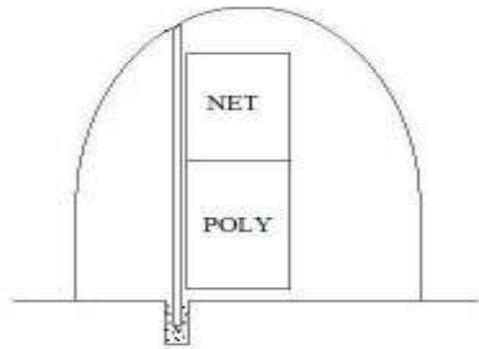
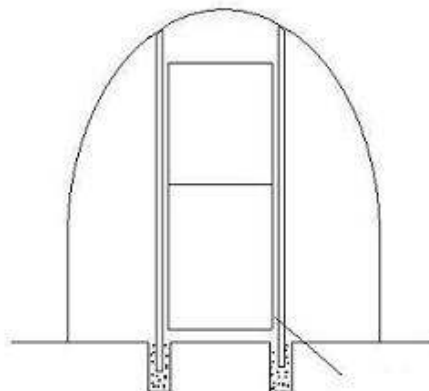

Fig36

Position and fix the second door post using the same method as fixing the first post



Slide the post around the hoop until a suitable gap is left between door and post. Use a 6" nail to gauge the gap.

Fig37

The timber lintel supplied should be cut to fit between the posts. **(Fig38)**

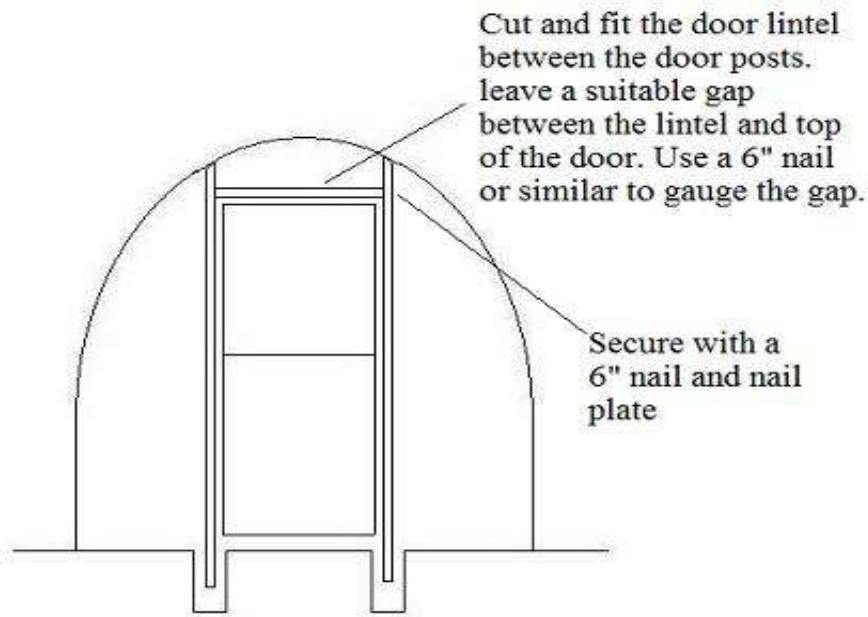

Fig38

Drill a 7mm hole through the side of each door post 1.5-inch above the top of the door. Sit the lintel in place between the door posts and on top of the door with a 6mm gap once again between lintel and door, fix in place with a 6-inch nail through the previously drilled holes **(Fig39)**. Nail a nail plate across each joint on the inside of the polytunnel **(Fig40)**.



Fig39



Fig40

*****Please note: When placing a polytunnel on a hard base, Angle Brackets should be used to secure the bottom of the Door Posts.*****

FORMING A REBATE FOR YOUR DOOR FRAME

In order to fix the cover around the door frame and give it the necessary strength to remain held in position under extreme weather, it is trapped in a rebate which must be formed around the outside edge of the door frame with 19mm x 38mm battens. These battens should be cut and nailed up each leg and across the lintel to the outside edge (nails spaced at 9-inch), the cover then comes over this batten and is trapped in place by another batten nailed to the door frame up against the first batten (**Fig41**).



Fig41

DOORS

*****MEASURE TWICE, CUT ONCE TO AVOID MISTAKES!*****

Your doors now have to be made to suit your chosen opening.

The width should be 10mm less than the opening and the height short enough to give adequate ground clearance.

Using a flat surface or bench take the two 2-inch x 1-inch x 1.8m door legs and cut to the required length (this will be the height of the door). Cut the 3 cross pieces to fit between the legs to give the overall width required.

Using 6 Corner Braces and screws, fix a cross piece between the legs at each end and one in the centre. These enable you to build the door square without checking (**Fig42**).



Fig42

Tack the net and polythene panel to each half of the door and get as much tension as possible on the polythene – a staple gun comes in handy here.

Cut two pieces of 19mm x 38mm batten the full width of the door and nail these on top of the net and polythene at each end, making sure there is a nail at each side of the joint of the frame. This is important as it gives the door added stiffness (**Fig43 and Fig44**).

Cut two battens to fit down the door legs and nail in position (nails should be about 4-inch apart). Lining the battens up to the inside edge of the door frame makes sure the clearance you built into the opening is maintained.

Cut and fix the final batten across the centre rail and trim off all excess material around the edges.

Example of a completed door, fixed in place to the door frame (**see Fig45 and Fig46**).



Fig43



Fig44



Fig45



Fig46

DOOR HINGES

Two, 4-inch butt hinges should be screwed to the inside edge of the door approx 9-inch from each end. Before screwing the hinges in place decide which way you want the door to open, remembering that the net panel is going to be to the top, and screw the hinges to the appropriate door frame upright.

*****VERY IMPORTANT:** As the door opens inwards it is important to prevent the top corner from damaging the polythene cover by placing a fixed stop or peg in the ground.***

DOOR CATCH – The catch is a simple hook and eye (**Fig47**).



Fig47

FINAL FIX

Check the structure all around for alignment and positioning of all the bars. If you are happy, all joints and P Clips can now be secured with a self drill screw (**Fig48**). In some cases this may be a combined fix of both joint and P Clip. These screws are held in the nut driver provided and, in the case of the P Clips, use one of the two small holes as a starter point for the screw (**Fig49**). Keep all screws to the inside of the polytunnel, away from where the polythene cover may rub.

*****It is MOST IMPORTANT that the hoops are screwed to the Foundation Tubes at this point.*****

*****If using Cover Tensioning Foundation Tubes, it is NOT required for the hoops to be screwed to the foundation tubes.*****



Fig48



Fig49

ANTI HOT SPOT TAPE

This is a self adhesive foam tape which is placed over each hoop. Anti Hot Spot Tape should be used just prior to covering your polytunnel. This tape should be placed over each hoop from ground to ground or to the top of the Side Rail. On the end hoops the tape should be placed at a 45-degree angle on the corner of the hoop in order to protect the polythene cover as it stretches around the hoop to the door frame.



Anti Hot Spot Tape

COVERING YOUR POLYTUNNEL

TRENCHING OPTION:

Dig a trench down each side of the framework at a distance of 4-inch out from the line of the hoops. At each end dig a trench at all 4 corners from the side trench to the door post. This trench should be a spade wide and approximately 14-inch deep. The edge of the trench nearest the polytunnel should be as straight and neat as possible as your cover will follow this line (**Fig50 and Fig51**).

*****Please note: Make sure you place the soil from the trench on the outside of the polytunnel.*****



Fig50 – Starting to dig the trench



Fig51 – Starting to dig the trench

Next, roll the cover out along the side of the polytunnel after checking and clearing the ground of sharp objects.

ONLY ROLL OUT YOUR COVER ON A CALM DAY AS YOU ARE EFFECTIVELY OPENING A LARGE SAIL.

This Thermal Anti Drip polythene must be placed with the Anti Drip side facing inside the polytunnel. The word "INSIDE" is written within the elephant logo.

With one person at each end, hold the edge of the sheet which, when pulled over the framework, will ensure the correct side of the polythene is on the inside of the polytunnel. Stretch the sheet tight along the length of the polytunnel and walk to the opposite side of the structure, taking the sheet over the framework and being careful not to snag the sheet on any protrusions.

The polythene is very strong and resistant to tearing so don't be afraid to pull it as hard as you can, but it is advisable to grip the polythene only around the edges as in the event of damage this area will be buried or can be trimmed off.

Centralise the sheet along the width and length of the polytunnel – You will find that the sheet will not reach to the ground at the ends, but this is correct and there is no need to worry (**Fig52**).



Fig52

- **STEP 1:** Cut a batten to fit along the door top between the battens forming the rebate, starting at one end of the polytunnel, trap the polythene with this batten in the rebate created earlier. The polythene should be smoothed out 4 inches either side of the door top centre and the batten nailed in place along this 8 inch length only (**Fig53**).

*****Please note: The nails supplied are designed to grip the wood and it is difficult to get them out without destroying the batten. Take care when positioning the batten to avoid any mistakes.*****

At the opposite end of the polytunnel the same method of fixing should be used, but this time the polythene should be pulled along the length of the polytunnel as tight as possible before nailing the batten in position.



Fig53

- **STEP 2:** Tension the polythene into the trench on one side starting in the middle – This is best done with one person at a hoop either side of centre (**Fig54**). Do not over tension but, when the cover is smooth from the ridge down into the trench, back fill the trench between the two people with the polythene forming a ‘U’ around the trench and the soil on top (**Fig55**). Using this method, work your way out to the ends.

Repeat this operation on the opposite side of the polytunnel, starting in the middle and working out – only this time get as much tension into the cover as possible. It is acceptable to stand on the cover in the trench to get the required tension.



Fig54



Fig55

- **STEP 3:** With just the four corners and door posts left, it will now be necessary to cut the polythene at the corners, but **ONLY** in the trench, to allow the cover to come smoothly around the ends.

Starting at the door top, grip the polythene and, while pulling tightly, twist the wrist to create a selection of pleats working out to the Door Post, nailing the batten as you go (**Fig56**). Repeat this same method down each door post (**Fig57**).



Fig56



Fig57

You should have run out of pleats by the time you reach the level of the straight side after which the polythene should form a smooth flat panel (**Fig58**).

Tension the cover into the trench at each corner and back fill with soil.

Trim off the excess polythene around the door opening (**Fig59**).



Fig58



Fig59

TIMBER BASE RAILS

This timber rail goes around the outside of the polytunnel framework at ground level leaving only the door opening (**Fig60**). The rails which make up the sides of the polytunnel are placed end to end and fixed at each hoop with a P Clip – **Please note:** The leg of the P Clips on each corner should face down the length of the polytunnel.

These side timbers should be left overhanging at each end. Wherever a joint in the rail occurs, cut a 6-inch piece of the same timber and nail across the joint on the inside (**Fig61**). Cut a length of timber to fit across the front of each door post and butt up to the overhanging side rail. To attach the end rail to the Door Post at ground level drill a 9mm hole through the end rail and door post and bolt in place with a 75mm cup bolt with a washer under the nut on the inside (**Fig62**). At the outer corner, a corner bracket is bolted behind the P Clip and comes around the hoop to bolt onto the end rail (**Fig63**). Use a 3-inch nail to attach the side rail to the end rail and cut off the overhang.



**Fig60 – Base Rail at ground level.
Side Rail at top of straight side.**



Fig61



Fig62

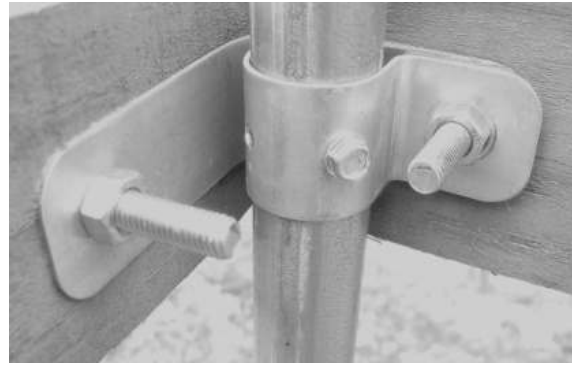

Fig63

FORMING A REBATE FOR YOUR BASE/SIDE RAILS

In order that the polythene cover can be attached easily and securely, a rebate needs to be formed around the Base Rails and Side Rails. To do this a batten is nailed around the top edge of any Base or Side Rails (**Fig64**). If Side Rails are used, the ventilation net should be trapped under this batten at the same time.



Fig64



Saw off (at an angle) any ends of the rebate which protrude at the corners.

COVERING YOUR POLYTUNNEL

TIMBER BASE RAILS OPTION:

Base Rails should be loosened off and raised approximately 2-inch off the ground (except where they meet the Door Posts) and re-tightened. Fit the cover using the same method as the trenching option but use battens to trap the cover in the rebate (**Fig65**). When covering is complete, loosen the Base Rail brackets (**Fig66**) and push the rails down until they touch the ground. Re-tighten and fix with a self drill screw (**Fig67**).



Fig65



Fig66



Fig67

TIMBER SIDE RAILS

Timber Side Rails are an exact replica of Timber Base Rails and should be assembled using the same method. Side Rails are placed at the top of the straight side of the polytunnel hoops on either one or both sides (**Fig60 – page 27**).

COVERING YOUR POLYTUNNEL

TIMBER SIDE RAILS AND VENTILATION NET OPTION:

Raise the Side Rail (which has previously been fixed at the top of the straight side of the polytunnel hoops) as you would with the Base Rail. The ventilation net should be in place and trapped under the rebate batten (**Fig68**). Cover the polytunnel using exactly the same method as for Base Rails. Lower the side rail and fix the “P” clip with a self drill screw (**Fig69**). Finally, tension the ventilation net down to the Base Rail and batten in place (**Fig70**).



Fig68



Fig69



Fig70

Congratulations!
You are now ready to begin growing and relaxing
in your ‘Premier’ polytunnel!